

FxLED™ Driver for Today's Appliances

In this article, we will explore how to use Lumissil's FxLED™ drivers to open up a new dimension in visibility by using specific colors to make the User Interface (UI) look sleek and informative.

For this application example, an air conditioning appliance was designed with sensors that detect a room's ambient air quality. The IS31FL3218 was selected to drive a dual colored linear display of 18 Red and 18 Green LEDs to graphically display the sensed air quality.

The IS31FL3218 is the optimum LED driver since it is comprised of 18 constant current channels each with independent PWM control. The average output current of each channel can be adjusted in 256 steps by changing the PWM duty cycle through an I2C interface. This fine level of LED dimming control is optimum for creating smooth color light transition effects such as a gradual modulation of LED brightness at turn ON and turn OFF resulting in an "LED Breathing" effect.

Gamma Correction

In order to perform a better visual LED breathing effect Lumissil recommends using a gamma corrected PWM value to set the LED intensity. Gamma correction, also known as gamma compression or encoding, is used to encode linear luminance to match the non-linear characteristics of an LED display. Since the IS31FL3218 can modulate the brightness of the LEDs with 256 steps, a gamma correction function can be applied when computing each subsequent LED intensity step resulting in changes in brightness that match the human eye's brightness curve. This results in a reduced number of steps for the LED intensity setting, yet still appears linear to the human eye.

Choosing more gamma steps results in a more continuous and smooth-looking breathing effect, especially when creating very long breathing cycles. The recommended number of gamma steps is defined by the breath cycle T. When T=1s, choose 32 gamma steps, when T=2s, choose 64 gamma steps. The user must decide the final number of gamma steps required to generate the preferred visual effect on the LED display which can vary with differences in LED characteristics. (See the gamma step comparison below).

C(0)	C(1)	C(2)	C(3)	C(4)	C(5)	C(6)	C(7)
0	1	2	4	6	10	13	18
C(8)	C(9)	C(10)	C(11)	C(12)	C(13)	C(14)	C(15)
22	28	33	39	46	53	61	69
C(16)	C(17)	C(18)	C(19)	C(20)	C(21)	C(22)	C(23)
78	86	96	106	116	126	138	149
C(24)	C(25)	C(26)	C(27)	C(28)	C(29)	C(30)	C(31)
161	173	186	199	212	226	240	255

Table 1-32 Gamma steps with 256 PWM step

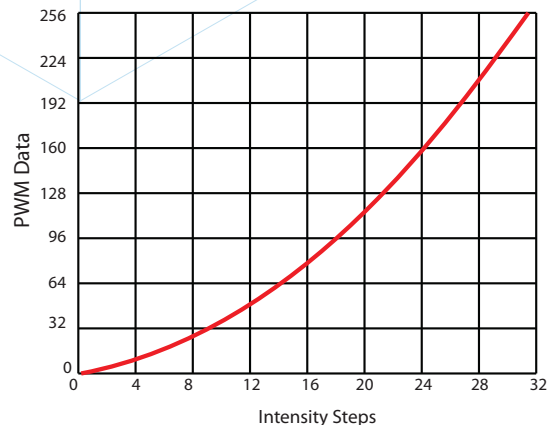

Fig 1 - Gamma Correction (32 steps)

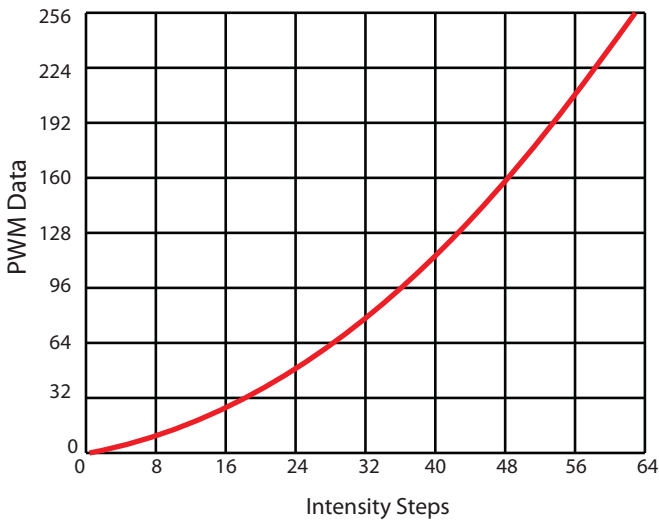

Fig 2 - Gamma Correction (64 steps)

C(0)	C(1)	C(2)	C(3)	C(4)	C(5)	C(6)	C(7)
0	1	2	3	4	5	6	7
C(8)	C(9)	C(10)	C(11)	C(12)	C(13)	C(14)	C(15)
8	10	12	14	16	18	20	22
C(16)	C(17)	C(18)	C(19)	C(20)	C(21)	C(22)	C(23)
24	26	29	32	35	38	41	44
C(24)	C(25)	C(26)	C(27)	C(28)	C(29)	C(30)	C(31)
47	50	53	57	61	65	69	73
C(32)	C(33)	C(34)	C(35)	C(36)	C(37)	C(38)	C(39)
77	81	85	89	94	99	104	109
C(40)	C(41)	C(42)	C(43)	C(44)	C(45)	C(46)	C(47)
114	119	124	129	134	140	146	152
C(48)	C(49)	C(50)	C(51)	C(52)	C(53)	C(54)	C(55)
158	164	170	176	182	188	195	202
C(56)	C(57)	C(58)	C(59)	C(60)	C(61)	C(62)	C(63)
209	216	223	230	237	244	251	255

Table 2-64 Gamma steps with 256 PWM step

In this application, each of the IS31FL3218 output channels was configured to drive two LEDs of the same color, Red or Green. This resulted in nine channels for Red and the other nine channels for Green; altogether 36 LEDs were used.

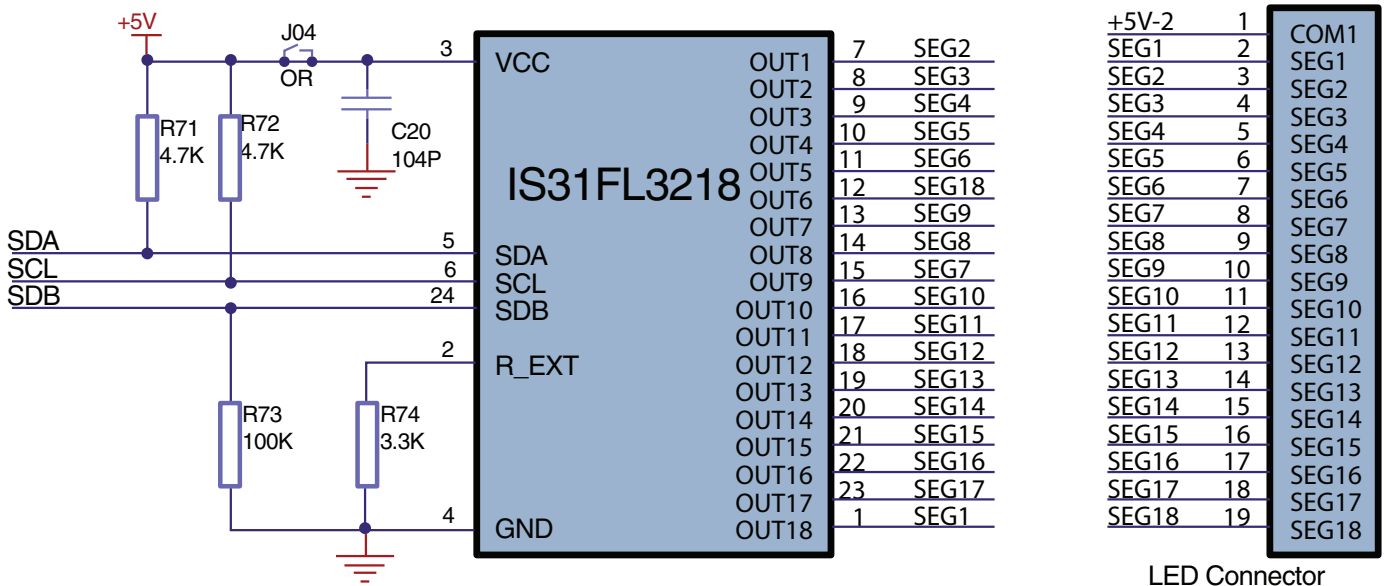

Fig 3 - IS31FL3218 schematic for driving Red and Green LEDs

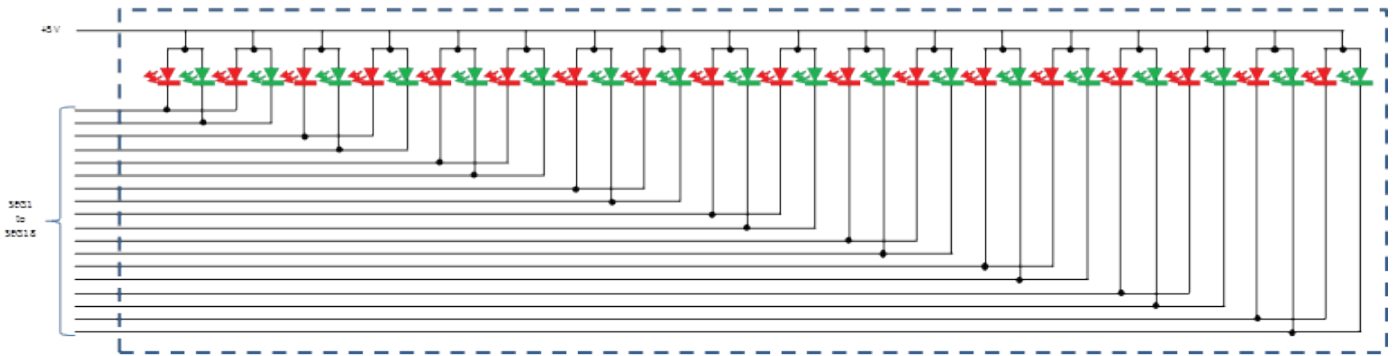

Fig 4 - Schematic of LED arrangement, Red and Green LEDs are paired

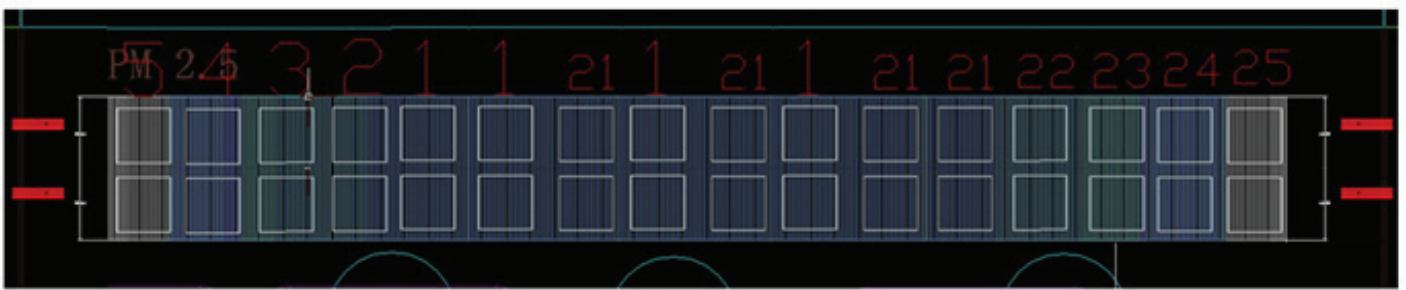

Fig 5 - LED bar placement of Red and Green LEDs

The 18 Red LEDs are put into a straight row while the other 18 Green LEDs are placed into another row beneath the Red row (Fig 5). With this arrangement it is possible to color mix the two rows of Red and Green LEDs to generate a hue of Red/Green colors. The pure Green color is used to indicate good air quality while the solid Red color indicates poor air quality. Colors obtained by mixing Red and Green, for example Yellow, would indicate a variation in levels of air quality between good and poor, see Fig. 6 below.

To make the display even more fancy and attractive, animation was added to the color legend. For this application the color illumination would initialize at the center of the bar graph and expand all the way to both the left and right sides. After the entire bar graph is fully illuminated the LEDs begin to turn OFF starting from the left and right sides, collapsing towards the center. The illumination cycle is continuously repeated so as to aesthetically attract attention to the air quality status, see Fig. 7 below.



Fig 6 - Color legend to indicate air quality

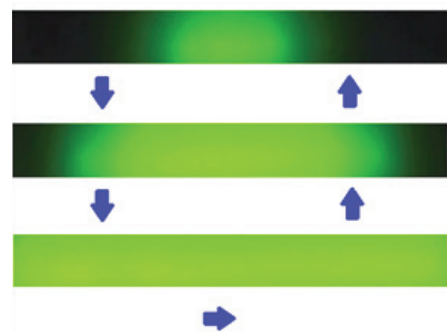

Fig 7 - Moving visual effect

Fig. 8 shows the block diagram of the implementation. A micro-controller (MCU) is used to send commands and data to set up the internal registers of the IS31FL3218 FxLED driver. The programmed FxLED driver outputs PWM signals on its output channels which drive the LED rows, this results in the desired color mixing and breath lighting effects.

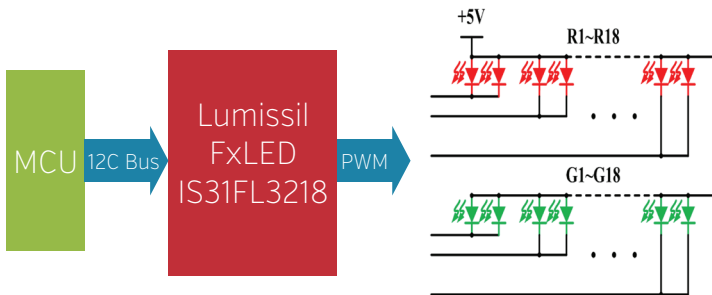

Fig - 8 Block Diagram

For this application, the Air Conditioner's main MCU is used to set up the values of the IS31FL3218's internal registers. Once the initial set up is completed, the main MCU is freed up from the necessity of performing LED control functions. It can resume its original control tasks for the air conditioner.

Color Mixing

Color mixing is accomplished by varying the channel to channel RED and Green LED brightness levels. To accomplish this, the 18 internal PWM registers are programmed so they output different pulse widths for each of the 18 output channels; the longer the pulse width the brighter the LED on that channel. The pulse width of each output channel is controlled by an 8-bit value stored in the FxLED PWM registers. The following equation shows how Red and Green color mixing is accomplished,
 $RED:GREEN = (x) : (y) = [0..255] : [0..255]$
 where, x and y are any integer values between 0 to 255.

For example,
 when $x=0, y=255$, GREEN color is obtained;
 when $x=255, y=0$, RED color is obtained;
 when $x=255, y=255$, YELLOW color is obtained;
 when $x=64, y=148$, GREENISH YELLOW is obtained;

Breath Effect

To further implement the gradually turn-ON and turn-OFF lighting effect, simply known as 'breathing' effect, the output is further divided into 32 or 64 brightness levels, as shown in Tables 1 and 2. Note that increasing the number of brightness steps will cause the 'breathing' effect to appear smoother.

After setting the (x,y) value to the desired color, it is next multiplied by the brightness value, n, to obtain the complete color mixing equation,
 $(RED:GREEN)_n = (x_n:y_n) = [(x*n/32):(y*n/32)]_n$

With gamma correction:
 $(RED:GREEN)_n = (x_n:y_n) = [(x*C(n)/255):(y*C(n)/255)]_n$

Where, n is an integer between 0 and 31;
 For gamma corrected values C(n), refer to table 1

The resulting numbers, x_n and y_n must be rounded off into an integer between 0 and 255. Please note that x and y can't be too small or color difference will not be noticeable.

For example, if the air quality is detected to be middle to good; the color to display is Greenish Yellow in which $x=64$ and $y=148$.

At time = 0, the LED is off, therefore, $n=0$, then,
 $(RED:GREEN)=(64*0/32:148*0/32)=(0:0)$

At time = 1, the LED starts to turn on at brightness level 1, $n=1$, then,
 $(RED:GREEN) = (64*1/32:148*1/32) = (2:2.625)$ or (2: 3)

At time = 8, the LED is in 25% bright, $n=8$, then, $(RED:GREEN)=(64*8/32:148*8/32)=(16:37)$.

By sending different values to each individual PWM register, different color mix and brightness can be achieved. The IS31FL3218 guarantees the output current of each LED channel is precisely matched so the color of each LED will be perfectly uniform on the bar graph. The result is an aesthetically pleasing and informative display worthy of today's sleek appliances.

ISSI FxLED Product Line

The FxLED family of Matrix, Multichannel and RGB LED drivers provides system designers with a wide range of options for bringing eye-catching color functionality to consumer electronics. For example, the Matrix line of LED drivers can be used to build an LED graphic panel for message boards and animated graphic displays; the Multichannel drivers can be used with light guides for informative appliance displays and the RGB drivers are perfect for low-cost color lighting. Overall, ISSI's broad portfolio of FxLED drivers simplifies the blending of Red-Green-Blue LEDs to produce a broad range of predefined colors and lighting sequences for driving 3 to 144 LEDs.

For more information, please visit our website at <https://www.lumissil.com/products/led-driver/fxled> or send your enquiry to marketing@lumissil.com